

SEAL CRAFT

Architectural Window Systems

Model 8150 HS-C50

Exterior Elevation

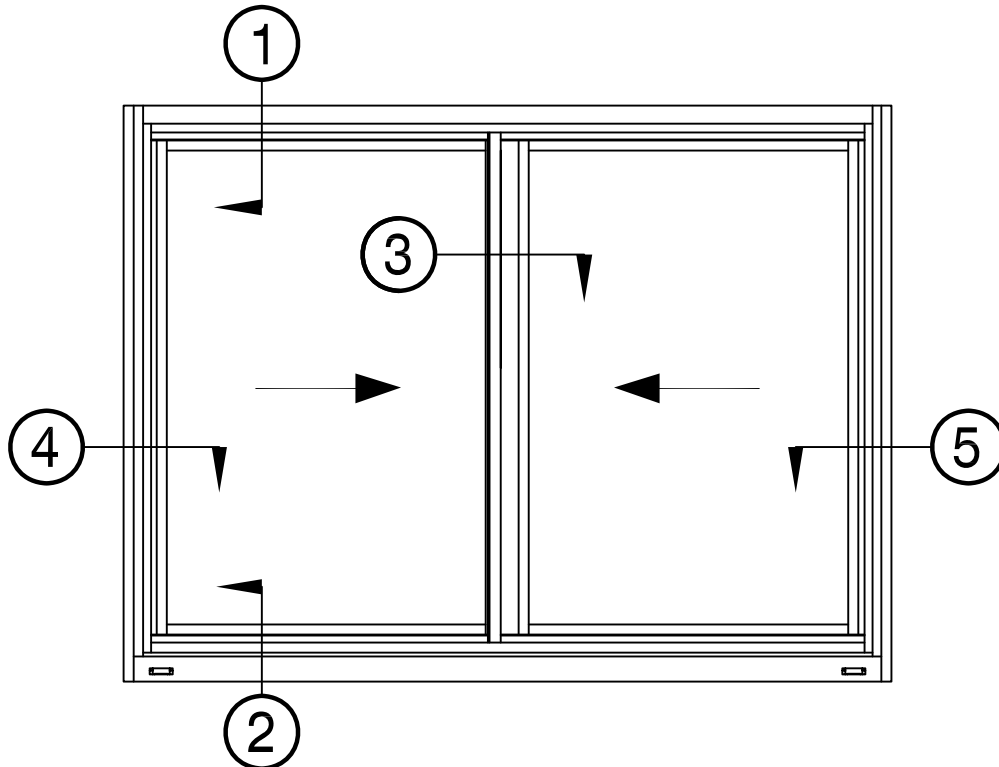

Horizontal Sliding Window

Structural Test Pressure up to 75 psf

Water Infiltration Tested to 7.5 lbf/ft²

Air Infiltration Tested to be less than .13 cfm/ft.²

Withstands wind velocity up to 139.8 mph at design pressure

Thermally Improved Frame & Sash

Maximum Size up to W-71" x H-60"

Minimum Size is W-27" x H-18"

SEAL CRAFT

Architectural Window Systems

Model 8150 HS-C50 Vertical Section/Jambs

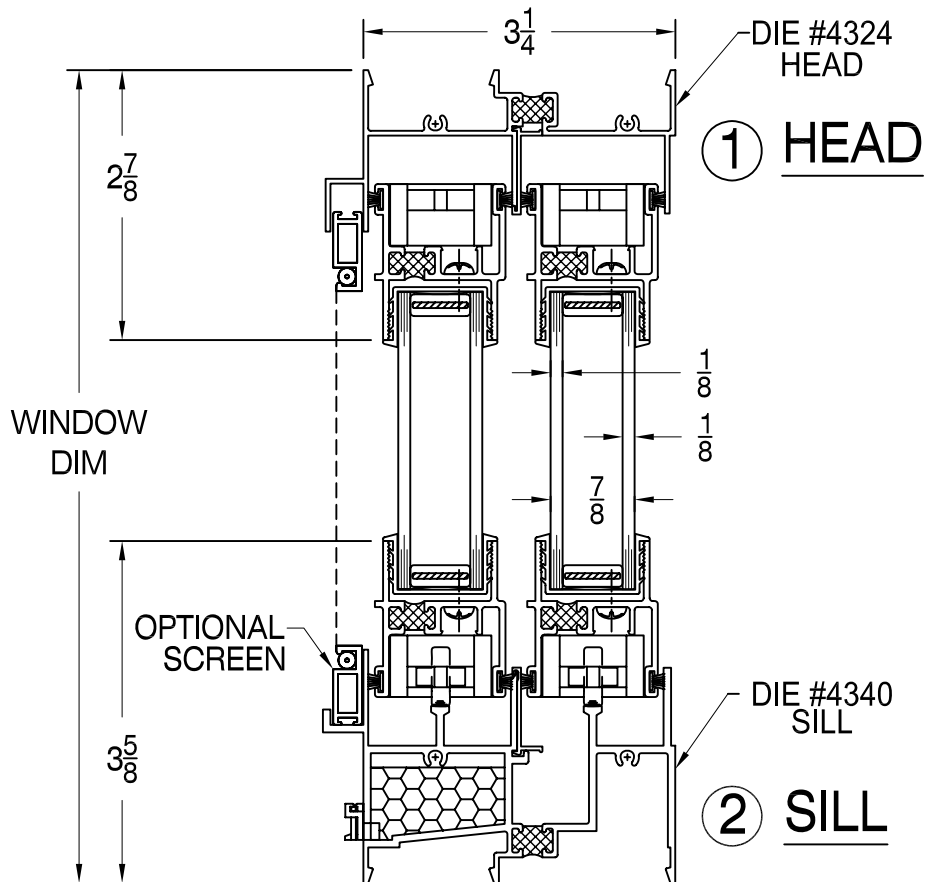
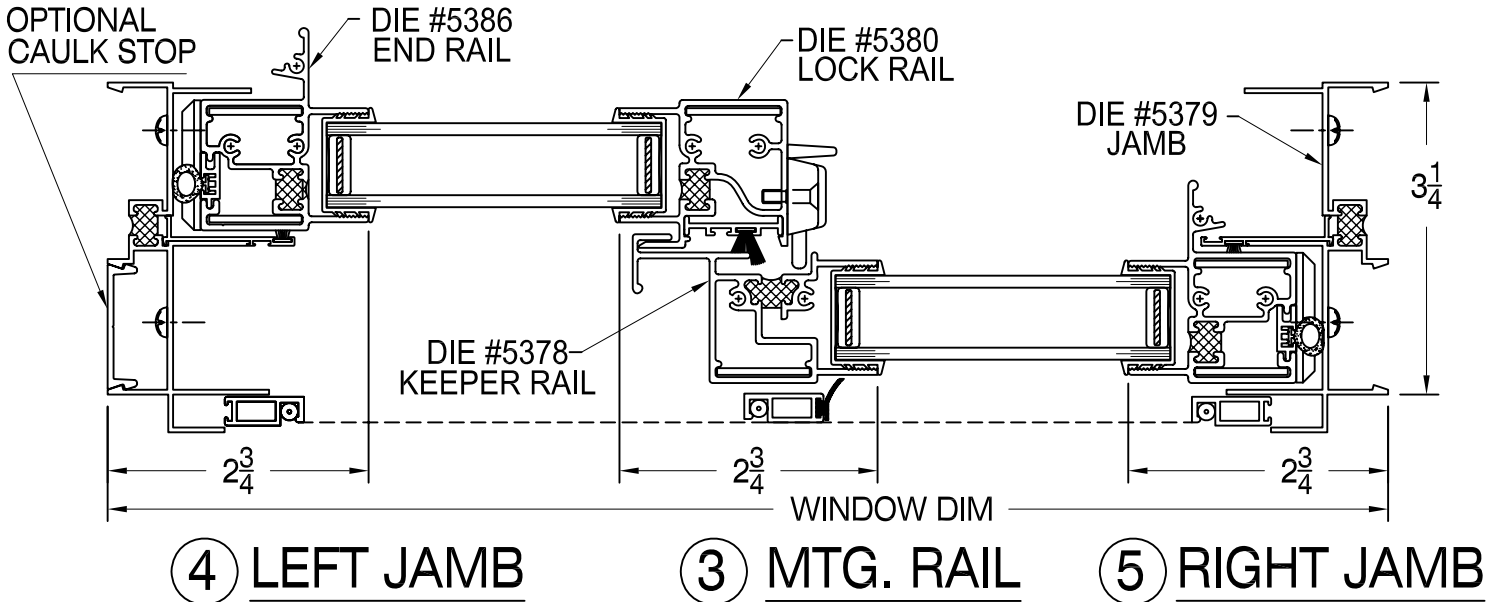

SEAL CRAFT

Architectural Window Systems

Model 8150 HS-C50

Accessories

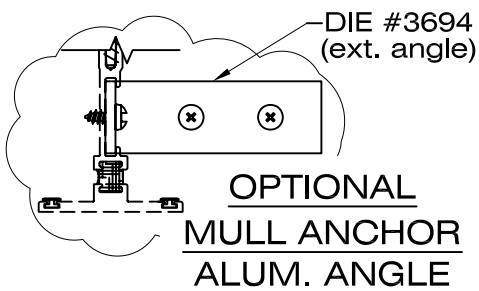
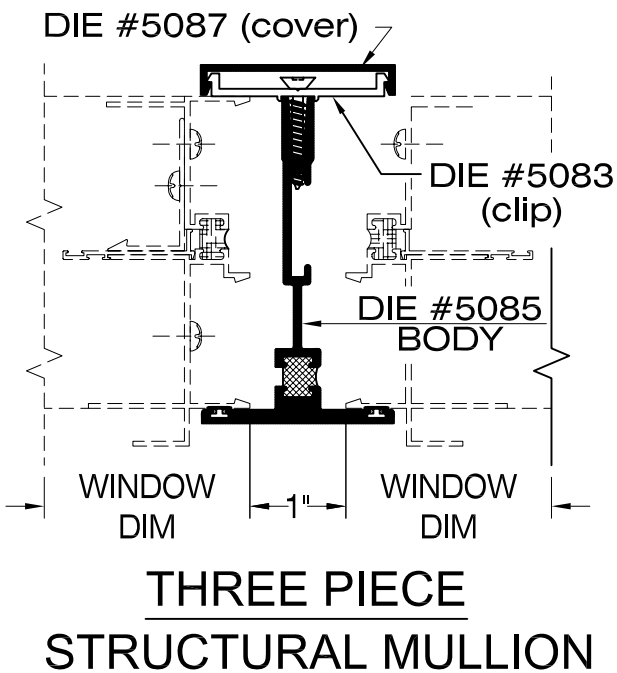
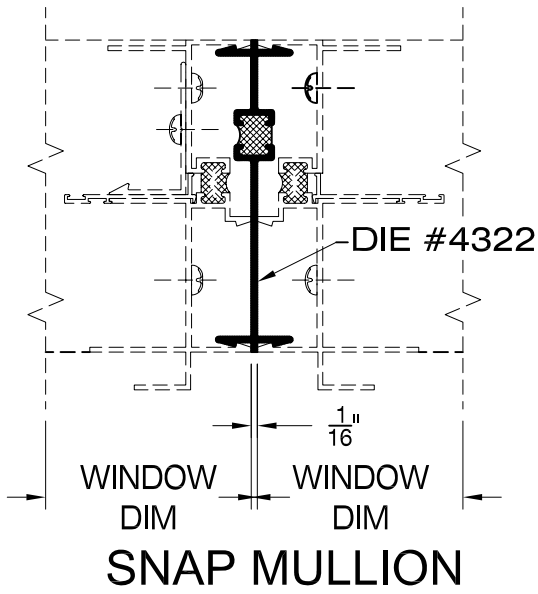

HALF SCALE

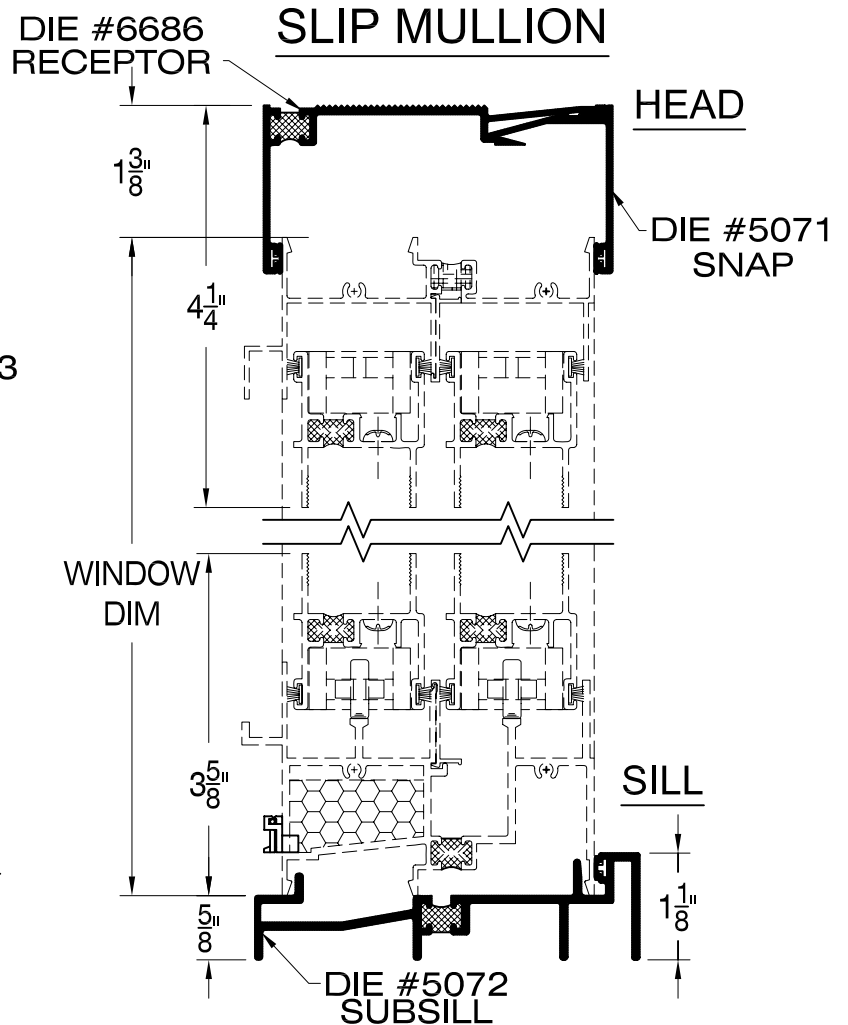
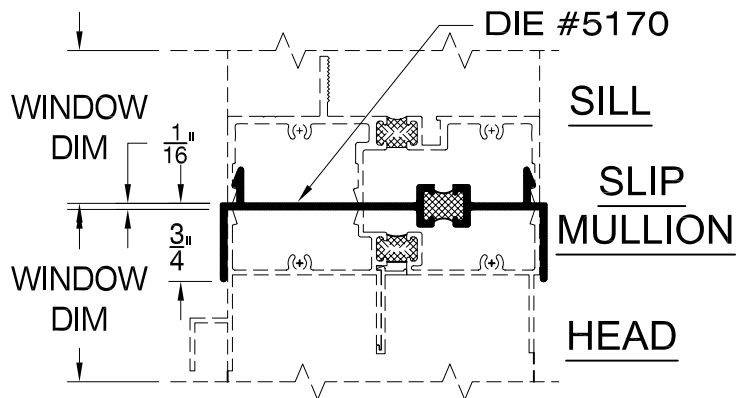

TWO PIECE RECEPTOR AND SUBSILL